

Security History & Architecture

(and other *VERY* scary stories!)



Dr. Steve G. Belovich



Why IT & Security History?

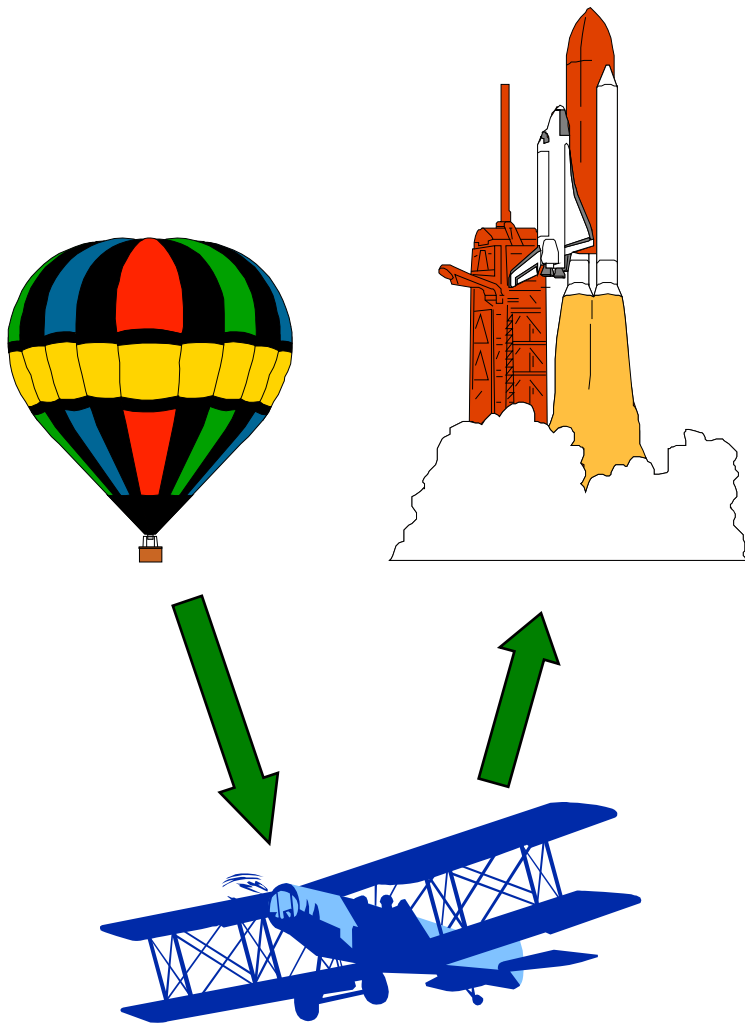

- It explains why we are in this condition.
- It significantly affects our options today.
- It can help prevent repeat errors.
- You can't get a solution if you don't understand the problem.
- Ignorance is very expensive!

The Evolution of Computing

Primates - 65 to 5 million BC

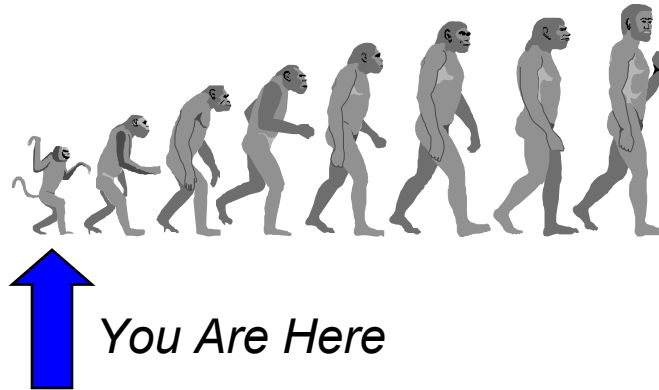

- 1830 - Charles Babbage Analytical Engine”
- 1937 - Howard Aiken Proposed “Automatic Sequence Controlled Calculator”
- August 1944 - “Mark I” completed
- 1946 - Von Neuman Architecture implemented in ENIAC/EDVAC
- 1951 UNIVAC 1
- 1952 IBM 701 - IBM’s first commercial box (19 units sold)

Key facts:

- Getting hardware working was the only issue.
- O/S concepts not there yet.
- Need for security non-existent.

The Evolution of Computing

Homo-Erectus - 2 million BC

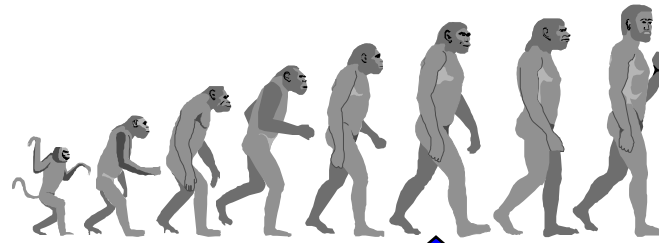

You Are Here

- 1960 - IBM 360 architecture used micro-Programming
- 1960 - Burroughs B5000
- 1964 - IBM 370
- 1973 - Arpanet
- 1975 - Cray 1 (64-bit)

Key facts:

- Hardware more reliable.
- Operating systems evolving.
- Private Networks invented.
- Multi-task O/Ss require task isolation and protection.
- Some basic security concepts formed.
- Small installed based allows lots of experimentation.



The Evolution of Computing

Homo Sapiens - 200,000 BC

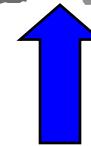
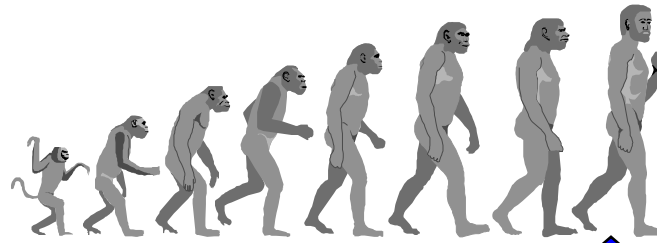

You Are Here

- 1979 - 4361/4381 (44-bit)
- 1981 - IBM 3081
- 1985 - Cray 2
- 1986 - IBM 3090
- 1990 - Internet
- 1996 - IBM Z-series

Key facts:

- Operating systems stable.
- Growing installed base - fewer new architectures.
- Multi-user O/S requires user isolation & protection.
- Public networks invented.
- Remote access requires isolation & protection.

The Evolution of Computing

Agriculture - 10,000BC

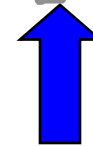
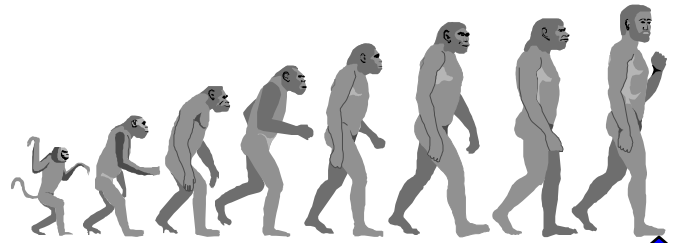

You Are Here

- 1965 - PDP-8/12 family
- 1970 - PDP-11 family (16-bit)
- 1977 - System 34
- 1977 - VAX family (32-bit)
- 1978 - System 38
- 1983 - System 36 - largest installed base of any computer
- 1986 - RS6000
- 1991 - Alpha family (64-bit)
- 1998 - IBM "P series" (64-bit)

Key facts:

- Hardware shrinks.
- Midrange machines introduced.
- Large installed base (200,000-400,000 machines).
- O/S has more features.
- Languages evolving.
- Significant remote access.
- Security matters.

The Evolution of Computing

Special-Purpose Genetic Manipulations

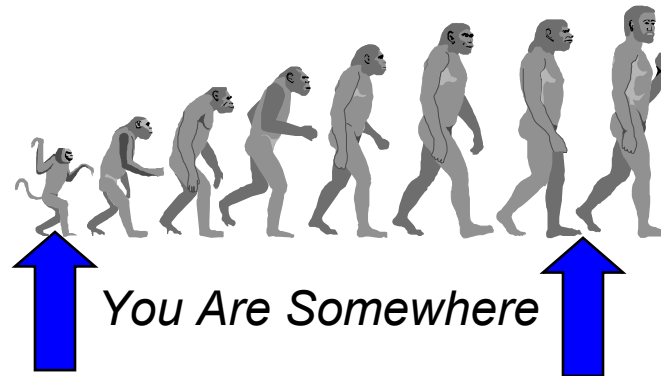

- 1970 - 4004 & 8008 micros
- 1974 - 8085
- 1977 - AMD2900
- 1980 - 8086 family
- 1980 - 68000 family
- 1980s - zillion special-purpose processors
- 1995 - Pentium family
- 2003 - Less than you think!

Key facts:

- Hardware really shrinks.
- O/S start out simple and dumb.
- Security deliberately eliminated.
- O/S grows to encompass what used to be applications.
- Cost is the driver; security & performance are secondary.
- Multimedia matters.
- Huge installed base limits change.

Security Research History



(What Secure Systems Must Do)



- Control access to information.
- Permit only authorized entities to read, write, create or delete information.
- Must have secure architecture.
- Must obey secure system model.
- Must have proper architecture, coding and deployment of the O/S, the application and all layers in between.
- Discovering security flaws then fixing them one-by-one does NOT work.

Economics 101

IT Spending 2000-2003

(Billions of Dollars)

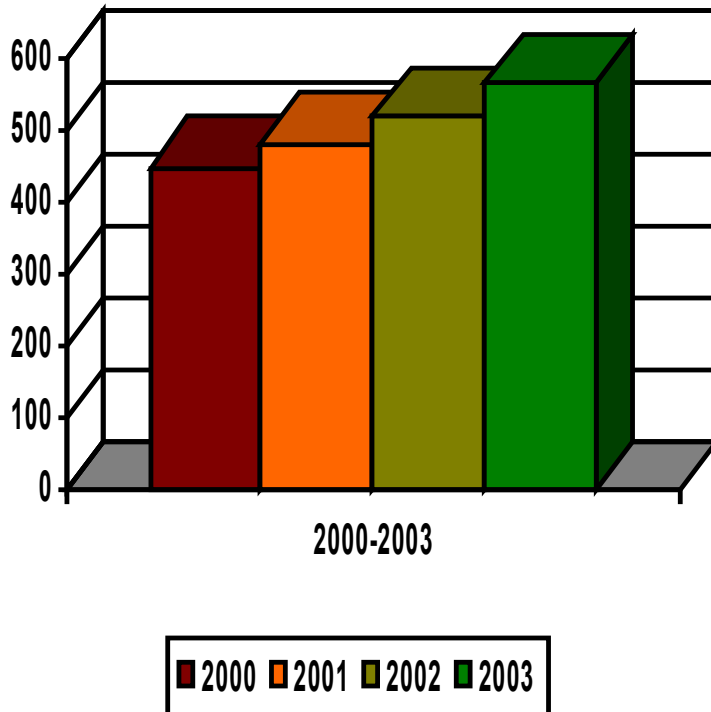

- Consumers control desktop market.
- No consequences for lack of adequate security.
- Demand for programming exceeds competent supply.
- Top 10 vendors have 55% of market share & 67% of workforce in packaged software.
- Until 9/11/01, security had had a high cost and low perceived market value.
- Buying bad stuff tells them to make more bad stuff!

Part 1 Summary

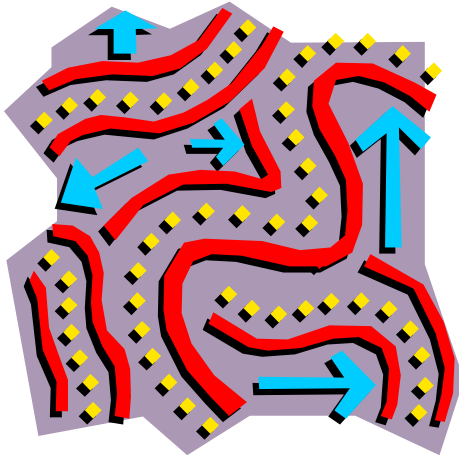

- Long & winding road for computer and IT system evolution.
- Low-end machines are consumer products where cost is king.
- Security was deliberately not included in desktop machines.
- Huge installed base prevents significant desktop re-design.
- Secure systems require the correct architecture - more in Part 2!

Security Architecture

- IT systems are built over time.
- Software is built in layers.
- Prior IT decisions can limit your choices today.
- Constant change is the rule.
- Must understand layers to direct security efforts properly.
- Must understand which IT operations matter most to your company.

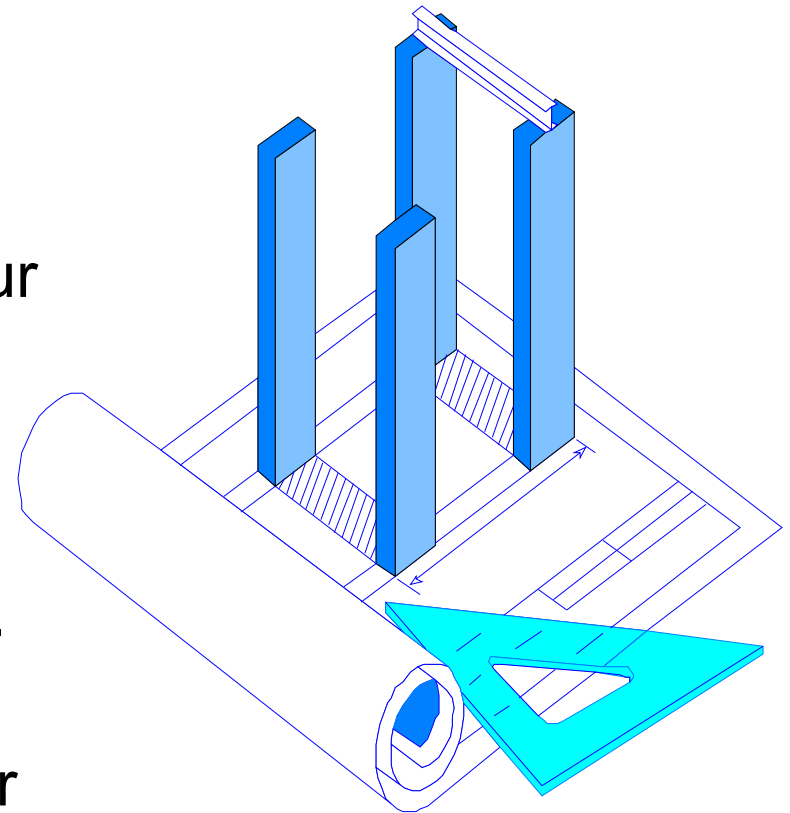

Software Structure

- **Business Applications**
- **Databases**
- **Network communication software, Internet**
- **Languages, Compilers & Tools**
- **Utilities & Libraries**
- **Operating system**
- **ISA (Hardware Layer)**

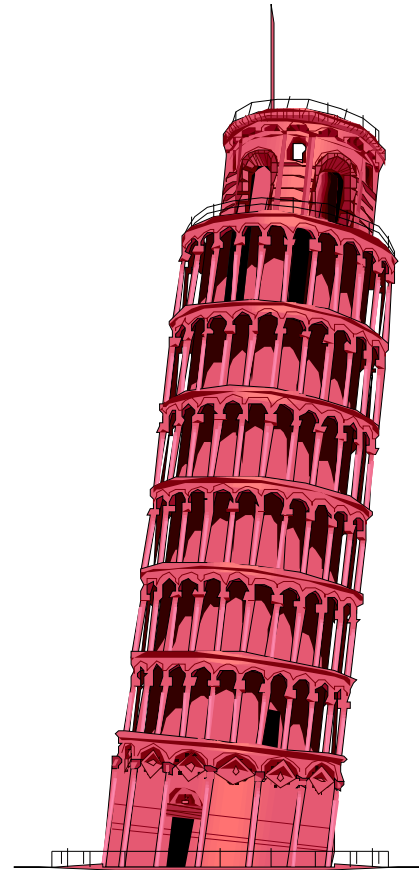

- **Libraries**
- **Books**
- **Chapters**
- **Paragraphs**
- **Sentences**
- **Words**
- **Alphabet**

- 1) Layers made by different & competing vendors
- 2) Minimal universal standards between layers
- 3) Inter-layer interfaces changing often and without warning
- 4) Interface features come and go from release-to-release

The OSI 7-Layer Model

Of network-oriented software

Protection Methods



No mechanisms for guaranteeing correct program operation.

Encryption, firewalls, anti-virus software, intrusion detection systems, etc.

Cardkeys, Biometrics, etc.

Critical Business Applications

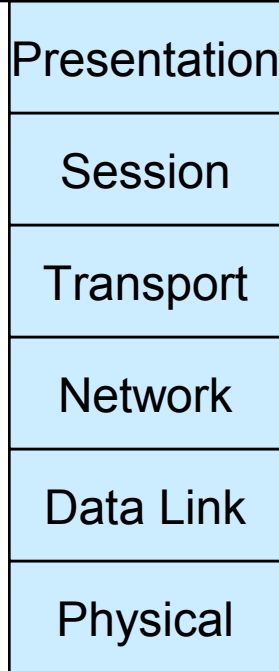

- The application does the useful work - it is the “payload” of your IT system.
- The 6 underlying logical layers are there to support and enable the application.
- All seven layers must be protected to have 100% security.
- Protecting just the lower layers via firewalls and anti-virus software is not enough - as experience has proven.



Secure System Requirements

■ Policy

- **Security Policy** - System must enforce a well-defined security policy.
- **Marking** - System must associate all objects with access control labels (sensitivity & access modes).

■ Accountability

- **Identification** - System must identify individuals and their various authorizations in a secure manner.
- **Audit Trail** - System must keep & protect audit trail so actions may be traced to responsible party.

■ Assurance

- **Evaluation** - System must have hardware/software mechanisms that can be independently evaluated to assure that policy & accountability are enforced.
- **Continuous Protection** - System must continuously protect trusted mechanisms that enforce policy & accountability from tampering.





Secure System Classification

(DOD)

- **D - Minimal Protection**
- **C - Discretionary Protection**
 - **C1 - Discretionary security protection** - separates users & data, uses credible controls to enforce access limitations on an individual basis.
 - **C2 - Controlled Access Protection** - users individually accountable for their actions, security audit trail, resource isolation.
- **B - Mandatory Protection**
 - **B1 - Labeled Security Protection** - security policy model, keeps integrity of sensitivity labels, sensitivity labels must be held in all major system data structures, demonstration of reference monitor implementation.
 - **B2 - Structured Protection** - formal security policy model, discretionary & mandatory access control enforcement extended to all subjects & objects, separation of critical & non-critical system elements, stringent configuration management controls, covert channels are addressed, relatively resistant to penetration.
 - **B3 - Security Domains** - Reference monitor mediates all accesses of subjects to objects, be 100% tamperproof, TCB (trusted Computing Base) only contains security-relevant code & data structures, system engineered for minimal complexity, security-relevant events are signaled, system recovery is required, highly resistant to penetration.
- **A - Verified Protection**
 - **A1 - Verified Design** - Functionally same as B3, full mathematical verification of design.



Secure System Classification

(NIST - National Institute of Standards & Technology)

(NIAP - National Information Assurance Partnership)

ISO 15408

- **EAL-1 - Functionally Tested** - independent testing of selected features.
- **EAL-2 - Structurally Tested** - independent testing of selected features using limited developer design data.
- **EAL-3 - Methodically Tested & Checked** - independent testing using limited developer design data, selective developer result confirmation, evidence of develop search for obvious vulnerabilities.
- **EAL-4 - Methodically Designed, Tested & Reviewed** - independent testing using low-level vendor design data, search for vulnerabilities, development controls, automated configuration management.
- **EAL-5 - Semiformally Designed & Tested** - independent testing of all of the implementation (TOE), formal model, semiformal conformance to design specs, vulnerability assessment for attackers with moderate potential.
- **EAL-6 - Semiformally Verified Design & Tested** - independent testing of 100% of TOE, modular & layered approach to design, structured presentation, vulnerability assessment for attackers with high potential, systematic search for covert channels.
- **EAL-7 - Formally Verified Design & Tested** - same as above, but all models, specs & presentations are formal, TOE is tightly focused on security functionality, amenable to formal analysis, design complexity must be minimized.

The Reference Monitor

(A Secure System Architecture)

- Enforces security policy
- Mediates all attempts by subjects to access objects
- Tamperproof database & audit trail **(no observation nor interference)**
- Small, simple & well-structured

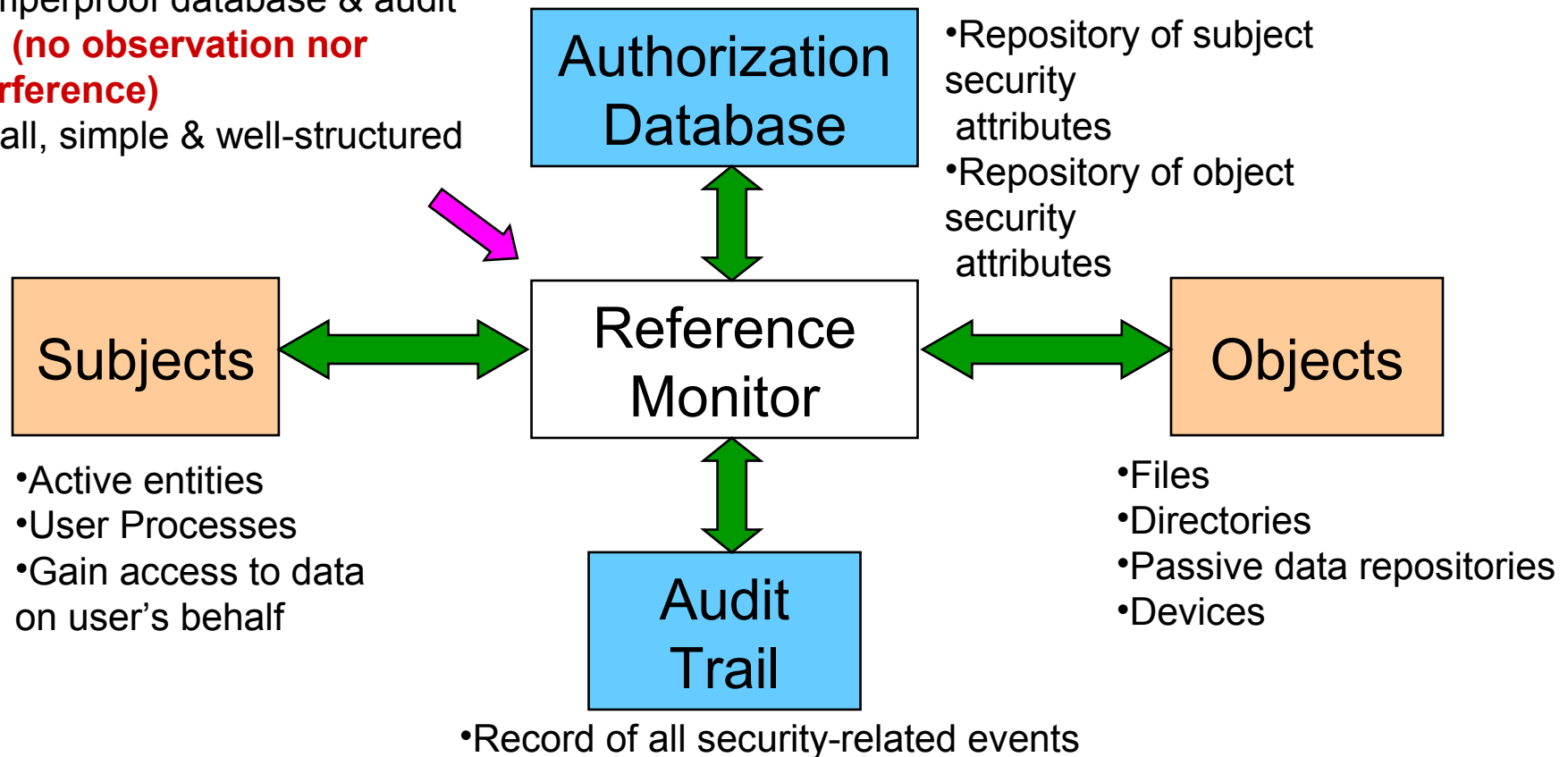

Where the RM is Used

- Reference Monitor (RM) must be part of O/S at lowest layer.
- RM must always control subject-object access.
- O/S cannot bypass RM at any time.
- RM cannot be “turned off”.
- All APIs must go through RM.
- Cannot “bolt on” the RM ex post facto.

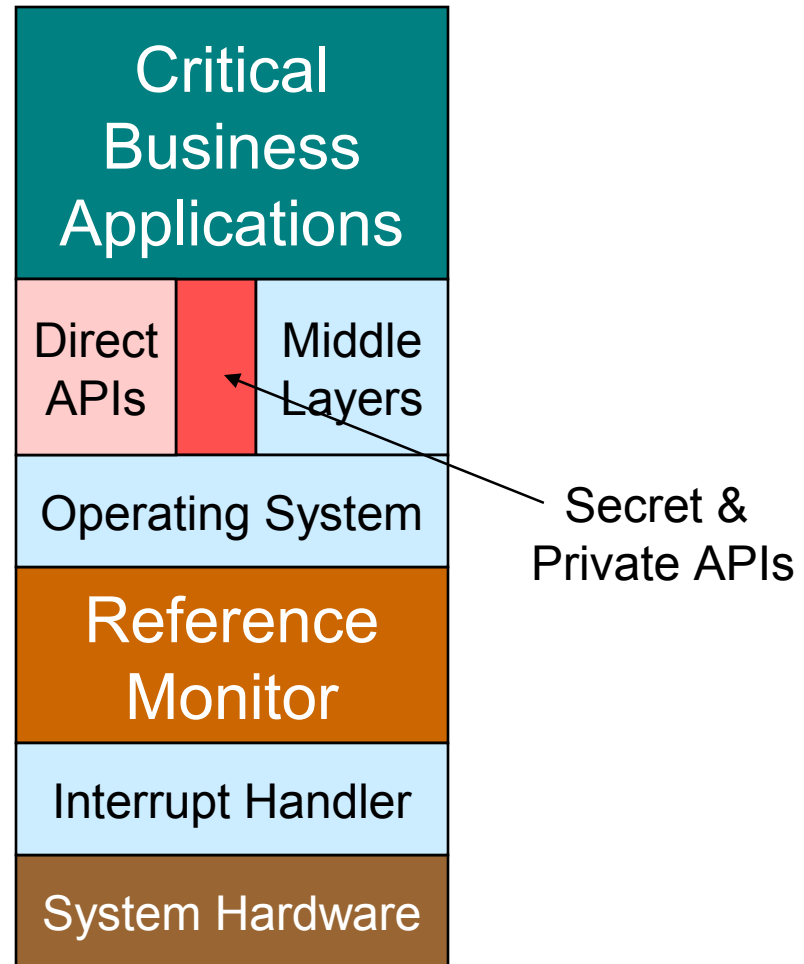

Part 2 Summary

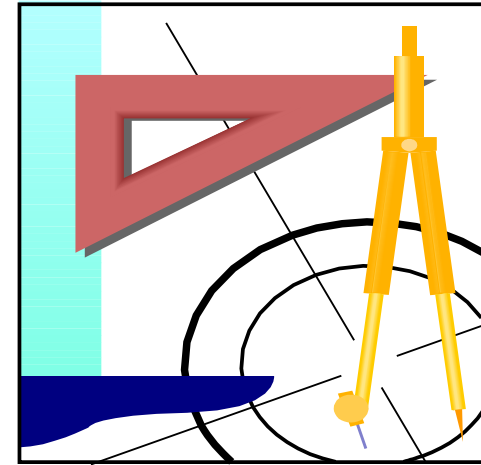

Critical Business Applications

Presentation

Session

Transport

Network

Data Link

Physical

- Software & IT systems are architected in layers.
- Software model shows why firewalls, Anti-Virus and Intrusion Detection systems will never be 100% effective.
- Reference Monitor - or equivalent - is required for a secure O/S.
- Applications must also adhere to proper security design requirements.
- Must use RM properly for success.
- Secure systems require the correct implementation - more in Part 3!

Security Implementation

Concept Summary

- There is no PC prophylactic!
- Security requires proper architecture and cannot be just “added-on”.
- Huge installed base gives little incentive for radical change.
- Simply going over each line of code - a famous Microsoft quote - won't fix the security problem.
- Non-secure platforms are ubiquitous.
- Have to



Operational Risk Analysis

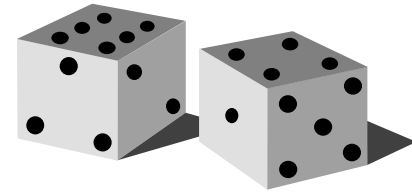

- Analyze existing IT operations.
- Identify critical ops that must run 24x7.
- Identify ops that organization can live without for a short time.
- Identify input & output data set locations for these ops.
- Identify which apps do these ops now.
- Identify how these apps are architected and deployed.

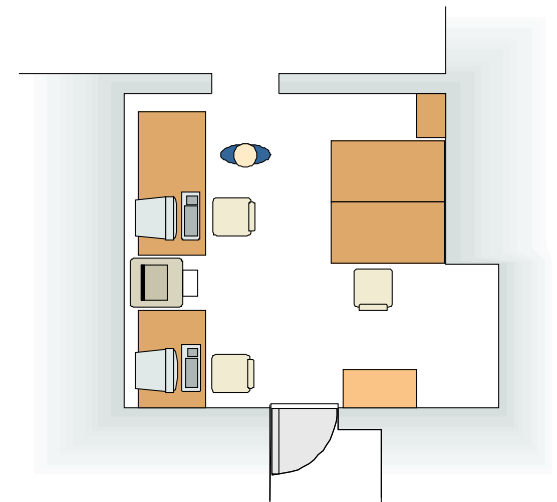

Deployment Guidelines

- Deploy critical apps only on secure platforms.
- Ensure that critical functionality is performed only by critical apps running on secure platforms.
- Segregate the data presentation, data analysis, network communication and database portions of your applications.
- Setup all applicable security controls for these apps and O/S.
- Force password management.

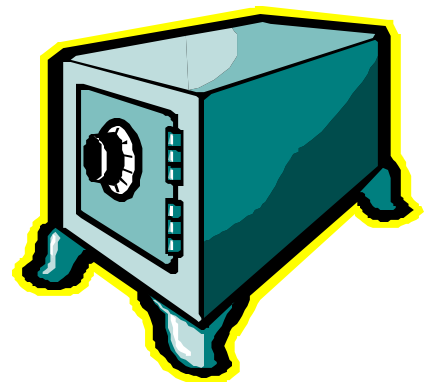
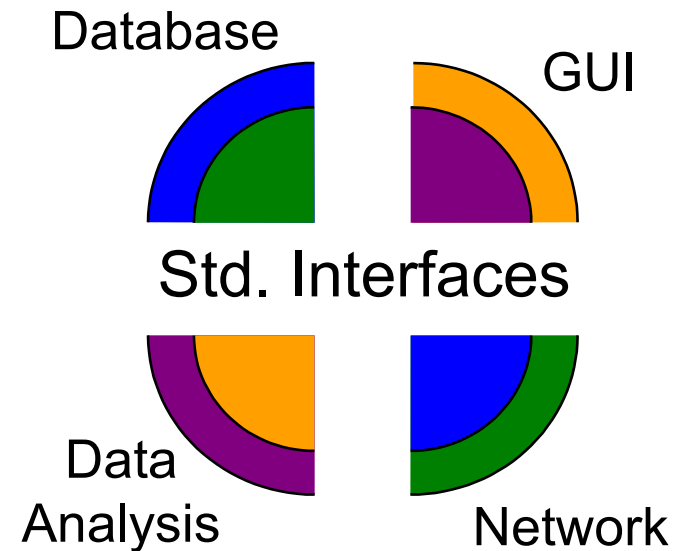



Deployment Example

Security Monitoring at NASA

- Critical operations:
 - Reading cameras
 - Reading other sensors
 - Analyzing data & drawing conclusions
 - Main operator interface
- Less critical operations:
 - General user interface
- Critical apps:
 - I/O drivers for sensors
 - Data analysis
 - Main operator interface

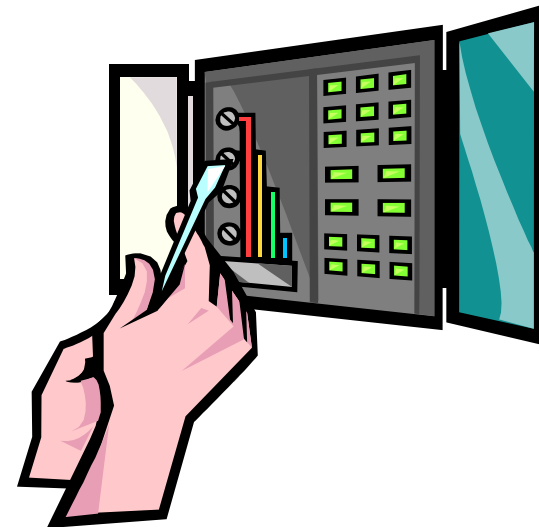
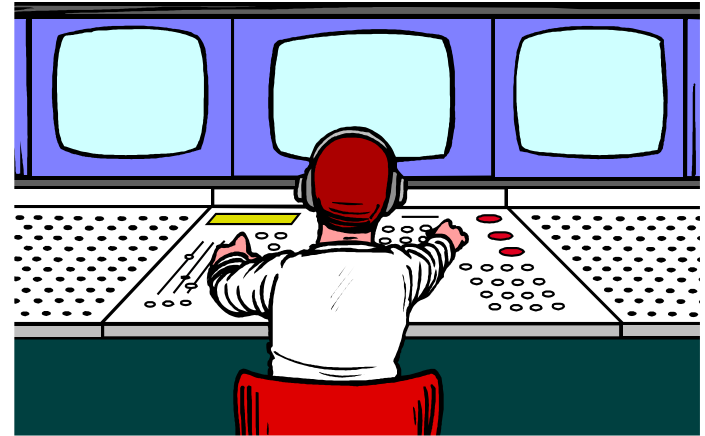

Deployment Architecture

GRC Mobile Unit Sensor List

- Flow Rate
- Temperature
- Conductivity
- C(orgamics)
- pH
- Various security sensors

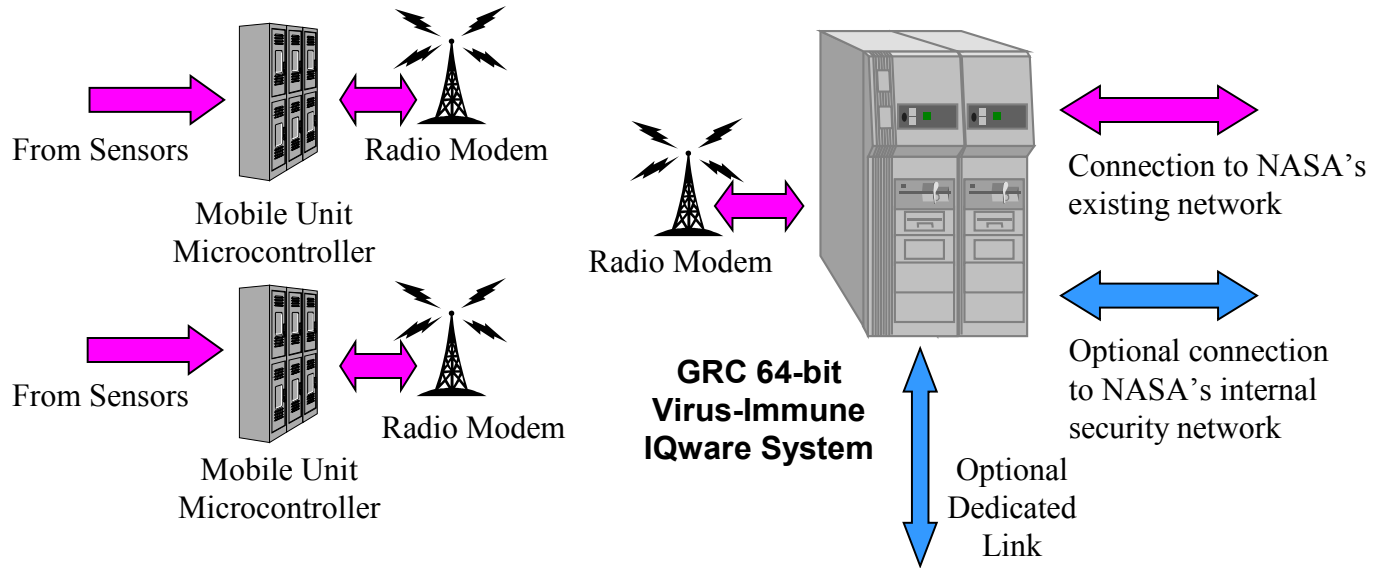

Plum Brook Mobile Unit Sensor List

- Flow Rate
- Temperature
- Conductivity
- C(chlorine)
- pH
- Various security sensors

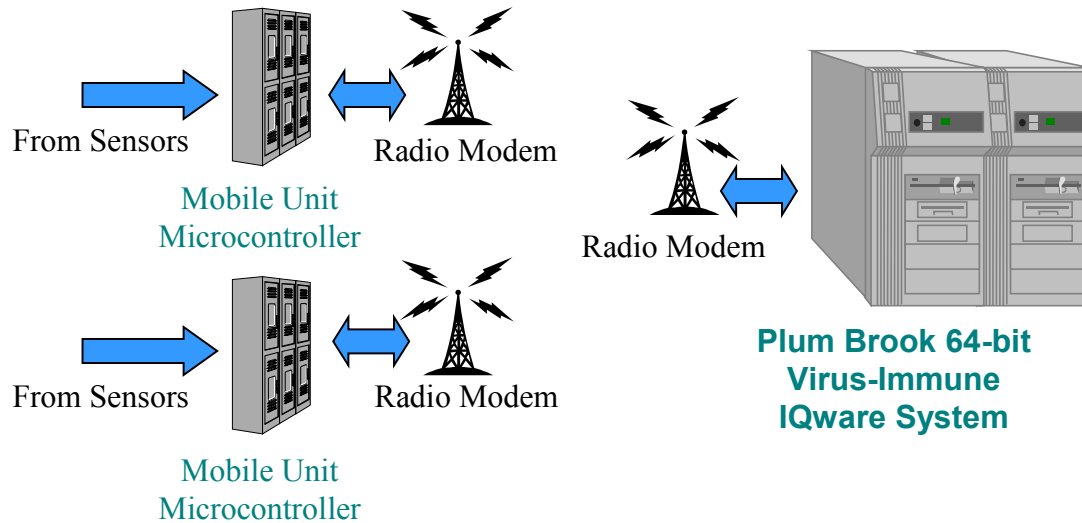

Notes:
Radios use proprietary non-standard protocol.



Part 3 Summary

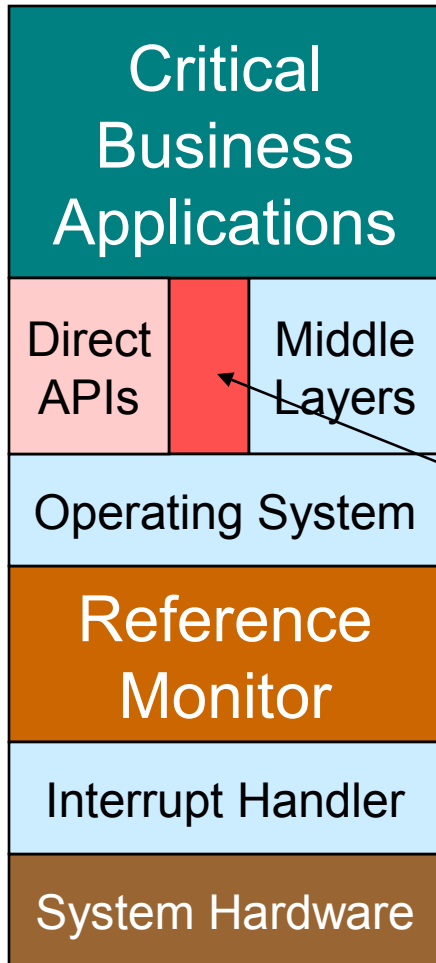

- Software has a vertical structure so ensure that your apps are on a solid base.
- Use the right tool for the job:
 - Use secure system for critical information.
 - Use secure system for critical applications.
- Deploy critical apps on secure platforms
- Use secure coding techniques
- Deploy apps carefully, using all available security controls.